

Laboratori Nazionali di Frascati

INF-66/48

I. Modena, V. Montelatici and F. Scaramuzzi : A LIQUID ^3He
TARGET FOR HIGH ENERGY NUCLEAR EXPERIMENTS. -

Estratto da: Nuclear Instr. and Meth. 44, 175 (1966).

A LIQUID ^3He TARGET FOR HIGH ENERGY NUCLEAR EXPERIMENTS

I. MODENA, V. MONTELATICI and F. SCARAMUZZI

Laboratori Nazionali di Frascati del CNEN, Frascati, Italy

Received 18 March 1966

A liquid ^3He target has been constructed for experiments on ^3He photodisintegration using the γ -beam of the Frascati 1.1 GeV electron synchrotron.

The cryostat is a development of a standard hydrogen-deuterium (HD) target in use with the Frascati electron synchrotron^{1,2}. For a detailed description of the HD target we refer the reader to the bibliography. However a brief summary of the characteristics of an HD target could be helpful. A reservoir of liquid hydrogen is connected with a cell, which acts as the target. A radiation shield cooled by liquid nitrogen surrounds the liquid hydrogen reservoir and the cell, except for two holes cut for the beam inlet and outlet: this reduces the heat input to the hydrogen reservoir and to the cell. The whole system is contained in a vacuum tank and in the upper portion of the cryostat (above the target) multiple layer shielding is provided to lower the heat input to the liquid nitrogen reservoir. To fill the target with liquid deuterium, the cell is isolated from the reservoir, deuterium gas from a constant volume tank is condensed in a coil immersed in the liquid hydrogen reservoir and fills the target. This sophisticated solution was chosen for the cryostat mainly to reduce both the quantity of liquid hydrogen present in the experimental hall and the frequency of fillings. In fact, the running time of the HD cryostat was very satisfactory, reaching two weeks. Another advantageous feature of this solution is the fact that different cells, with different geometries, can be mounted on the same cryostat. This is the main reason why this kind of cryostat was developed in place of the old Littauer-Wilson type^{3,4}. Facilities are provided in such cryostats to empty and fill the cell, while liquid hydrogen is in the reservoir. Liquid ^4He can be put into these cryostats in place of hydrogen in order to have a liquid ^4He target, but the evaporation rate is pretty high ≈ 0.2 l/h, corresponding to a running time of about 1 day.

The main modifications of the HD cryostat which led to the cryostat described in this note are as follows:

To reduce the heat input all the piping necessary to permit the emptying and filling of the cell have been eliminated, leaving only the liquid level controls. ^3He is condensed in a coil passing through a bath of liquid ^4He under reduced vapor pressure (≈ 78 mm Hg =

2.5°K). In order to be sure that the target is full of liquid, the gas is supplied until the pressure above the liquid ^3He is slightly higher than the vapour pressure at that temperature (≈ 380 mm Hg). To cut the heat input to both ^4He and ^3He containers a liquid hydrogen shield and an outer liquid nitrogen shield have been realized.

Fig. 1 shows a schematic drawing of the *cryostat*. The vacuum tank contains the three coaxial containers which are thermally insulated from each other by the vacuum and by thin-walled stainless steel tubing; a is the liquid nitrogen container, b is the liquid hydrogen container, c is the liquid ^4He container, d is the target containing liquid ^3He , e is an extension of the main liquid nitrogen container, connected with the latter through the coil f, which at the same time cools shield g. This shield is fastened to the tank e simply by means of screws. Another inner and colder shield h is fastened in the same way to the hydrogen container b. The ^3He condenser i consists of a copper tube (3 mm o.d.; 1 mm i.d.) wound in a helix, joined to a straight upper section made of stainless steel tubing (2 mm o.d.; 1.6 mm i.d.). j is a pack of multiple layer shielding which reduces the heat inlet to the nitrogen reservoir. In the two cooled shields g and h, holes are cut in the directions of the incoming γ -beam and of the emerging particles, in order to reduce the background radiation in the experiment. In the directions of the holes, the only protection against thermal radiation at room temperature is a single sheet of thin aluminum foil (thickness 0.01 mm). The outer tank is made of three different pieces connected to each other with O-ring systems. The lower part has a large window on which a film of 0.175 mm thick mylar is glued with araldite. The ^4He and ^3He tanks are made of three pieces fastened with indium seals l. The pumping system for the insulating vacuum is connected at the bottom of the cryostat. The three sets of spacers, m, made of nylon thread, with four spacers in each set, have a double function: firstly to prevent any contact between parts due to deformation during the thermal cycles, and secondly to give the position of the centre of the target with a precision of ~ 1 mm. The upper set determines the position of the liquid N_2 tank with

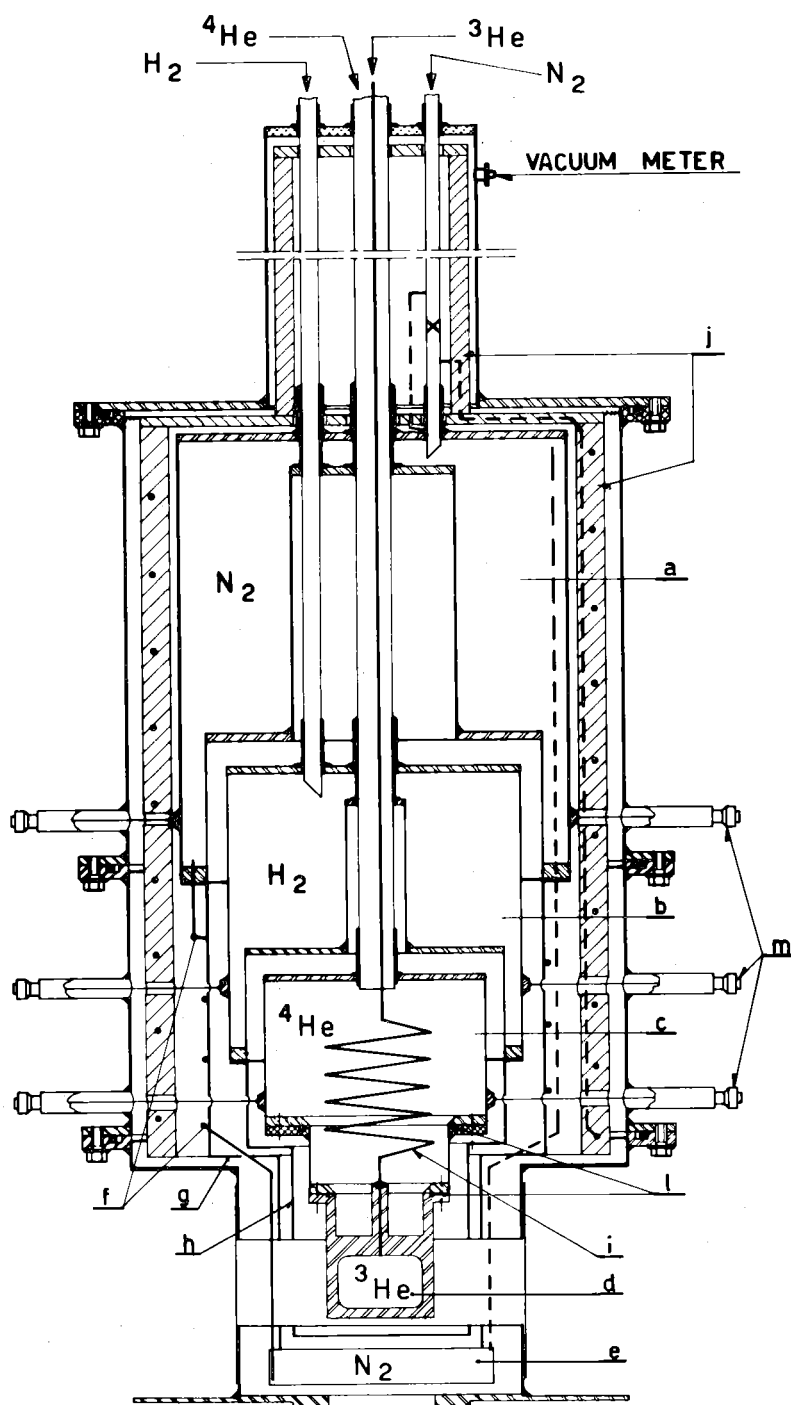

Fig. 1. Schematic drawing of the cryostat. The symbols are explained on page 175.

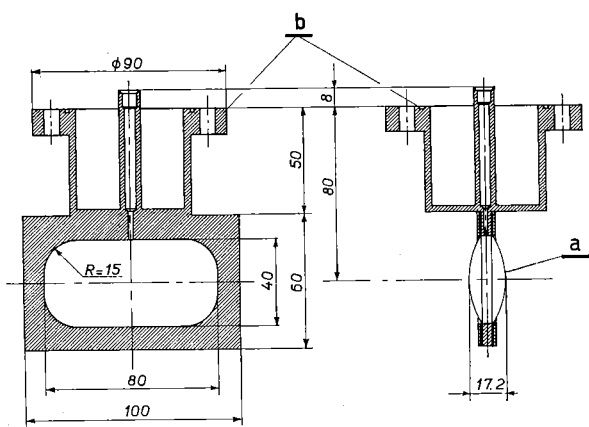

Fig. 2. Two perpendicular vertical sections of the cell (target). The dimensions are given in mm.

respect to the outer tank, the middle set does the same for the liquid H_2 container, the lowest for the liquid ^4He container.

The cell has the shape of a cuboid 4 mm thick, 8 cm wide, 4 cm high (fig. 2). The thin nickel walls a (0.03 mm thick) were welded with cusil (trade mark Wesgo, USA) alloy in a hydrogen atmosphere to a nickel block b. In order to ensure the best possible thermal contact between the liquid ^3He in the cell and the liquid ^4He bath, the block was made in one piece and contains liquid ^4He in the upper section.

Due to the pressure difference between the ^3He container and the vacuum space outside, the thin nickel walls assume a round shape which has a maximum thickness of 17.2 mm in the center. A map of the thickness has been made for the users of the target.

We have attempted to use a range of materials, and various types of welding. At present we have begun the construction of a cell made with stainless steel films welded in a vacuum oven to a nickel body.

Fig. 3 shows a schematic diagram of the flow circuit. The ^3He line is extremely simple. It consists of a tank of volume 13 l, which is initially filled with ~ 24 l ntp of ^3He , at a pressure of ~ 1.9 atm (absolute). One stopcock separates this tank from the condenser line. When the target is cooled to $\sim 2.5^\circ\text{K}$, the stopcock is opened and the ^3He condenses in the target. The quantity of ^3He is such that all the cell and part of the condenser are filled with the liquid and the rest of the gas remains in the tank at about the vapour pressure above the liquid. The ^4He circuit contains a normal evaporation line and a line served by a vacuum rotatory pump. A manostat type pressure regulator [Croft and White⁵], keeps the ^4He vapour pressure at the desired value and thus the temperature constant.

Normal evaporation lines are provided both for the hydrogen and for the nitrogen. For all three lines (^4He , H_2 and N_2) gas flow counters are provided to control the behaviour of the cryostat and to know at

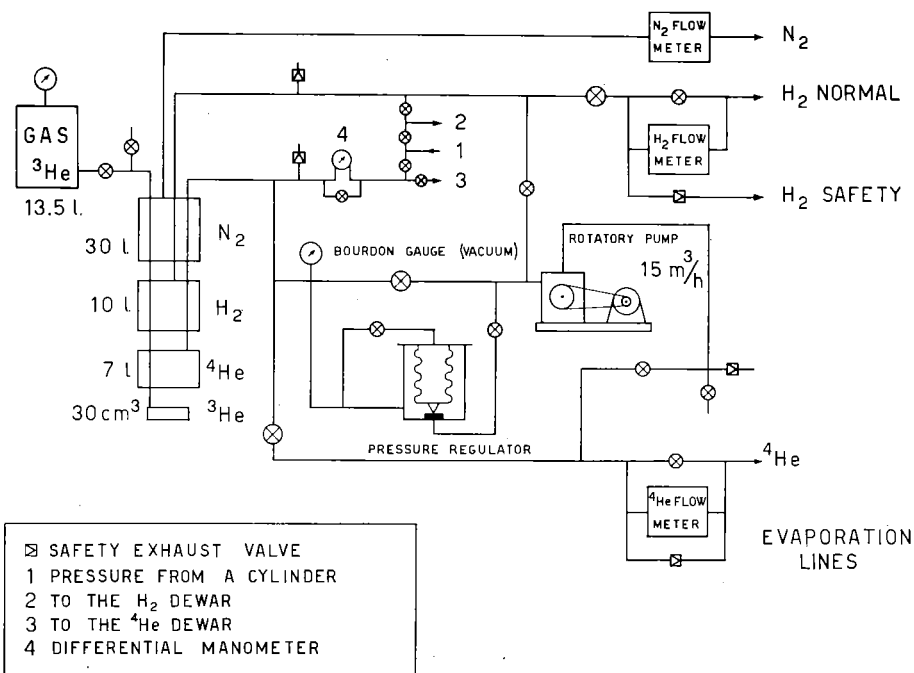

Fig. 3. Schematic diagram of the flow circuit. The pressure lines 1, 2 and 3 and the differential manometer 4 are used to supply pressure for the H_2 and ^4He transfer.

TABLE 1

Liquid	Capacity of reservoir (l)	Evaporation rate at equilibrium (l/h)	Running time (h)	Filling time (min)
N ₂	30	0.15	190	50
H ₂	10	0.034 (0.015)*	250	50
⁴ He (at 4.2°K)	7	—	—	30
⁴ He (at 2.5°K)	4	0.03	120	—

* Evaporation in presence of ⁴He.

any time the various volumes of liquids in the cryostat (this can also be done for the ⁴He and H₂ by direct measurement of the liquid level).

Vacuum tests have been made, step by step, on the cryostat, as for all the HD cryostats. For the cold parts, the tests have been made at liquid nitrogen temperatures as well.

Special care has been dedicated to the safety tests for the thin walled nickel cell. A few dummy cells have been made and broken. The cell to be used was tested at a

pressure double the working pressure and an accurate search for vacuum leaks was then made both at room temperature and liquid nitrogen temperature.

After the usual tests in the laboratory, the cryostat is already working on a γ -beam and the first preliminary measurements on ³He photodisintegration have been made. Table 1 summarizes the characteristics and performance of the cryostat.

The authors wish to thank the personnel of the Cryogenic Group, in particular Messrs. A. Bellatreccia, L. Martinis, L. Siracusano. Thanks are also due to Messrs. P. L. Belli and L. Righini of the Technological Group for the construction of the cell.

References

- 1) V. Montelatici, Lab. Nazionali di Frascati, int. rep. LNF 62/20 (1962).
- 2) V. Montelatici, Nucl. Instr. and Meth. **29** (1964) 121.
- 3) R. Littauer, Rev. Sci. Instr. **29** (1958) 178.
- 4) R. Wilson, Rev. Sci. Instr. **29** (1958) 273.
- 5) G. K. White, *Experimental techniques in low temperature physics* (Clarendon Press, Oxford, 1959) p. 206.